

+GF+ SIGNET 515/2536 Rotor-X Flow Sensors



Features

- PVDF or Polypropylene molded sensor body
- Simple Insertion Design
- Wide Turndown Ratio of 66:1
- For DN15 to DN1000 (0.5 to 36 in.) pipes
- Self-powered Flow Rate (P51530-XX)
- Process Ready Signal (3-2536-XX)
- Extended length for wet-tap installations available

Application

- Pure Water Production
- Filtration systems
- Chemical Production
- Liquid Delivery Systems
- Pump Protection
- Scrubbers

Description

Invented over 25 years ago by +GF+ SIGNET, the Rotor-X paddle-wheel insertion-flow sensor is a proven flow sensor. These highly repeatable, rugged sensors offer exceptional value with little or no maintenance required. Installation is simple with +GF+ SIGNET's comprehensive line of fittings for all pipe materi-

als in sizes from DN15 to DN1000 (0.5 to 36 in.). Output signal of the 515 is a sinusoidal frequency capable of driving a self-powered flowmeter (3-5090). The 3-2536 has a process-ready open-collector signal and can operate to flows as low as 0.1 m/s (0.3 ft/s).

Options

Rotor-X Sensors	Instrument Options								
	3-8550-1	3-8550-2	3-8550-3	3-5090	3-5075	3-5100	3-5500	3-5600	3-9010
P51530-XX	●	●	●	●	●	●	●	●	●
3-2536-XX	●	●	●		●		●	●	●

Technical Features

- 1/2 in. NPT Conduit Connection
- Large bail simplifies insertion/removal
- High-strength ring nut with provision for lead seal installation
- Dual O-ring seal (Viton® standard, EPR optional)
- Molded one-piece black glass-filled Polypropylene or natural PVDF body
- Multiple pin materials
- Open-cell rotor with material options

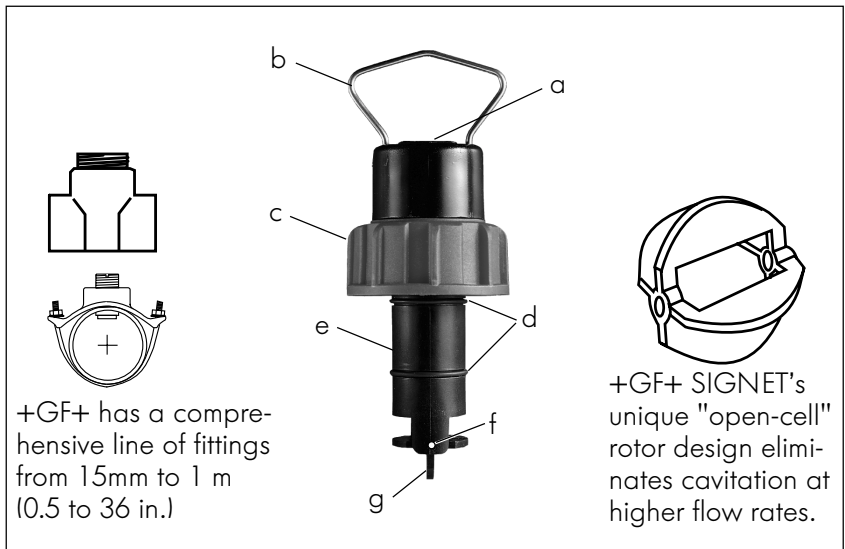

Dimensions

515/2536 Sensor

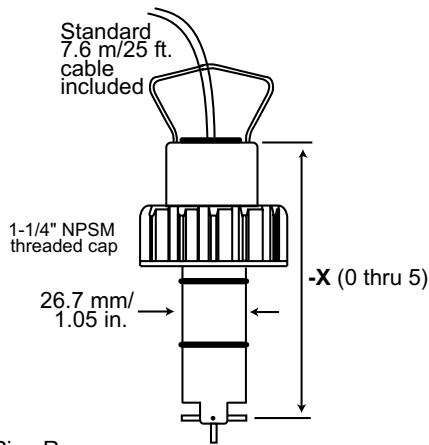

Pipe Range:

- 1/2 to 4 in. -X0 = 104 mm/4.1 in.
 - 5 to 8 in. -X1 = 137 mm/5.4 in.
 - 10" and up -X2 = 213 mm/8.4 in.
 - 1/2 to 4 in. -X3 = 219 mm/8.6 in.
 - 5 to 8 in. -X4 = 254 mm/10 in.
 - 10" and up -X5 = 331 mm/13 in.
- } Wet-tap Lengths

8510 / 8512 Integral Sensor with Transmitter (sold separately)

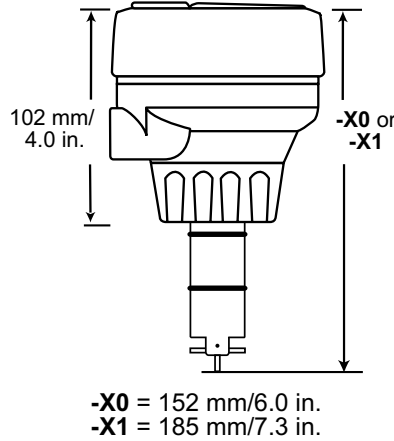



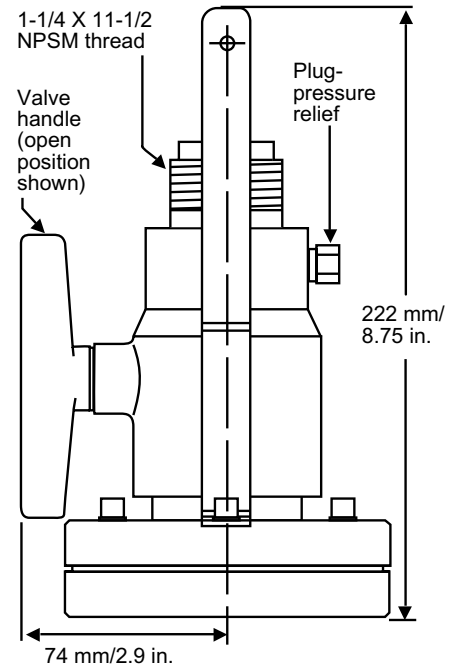





319 Wet Tap Assembly

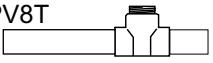

- Adapts to SIGNET flow fittings
- Extended 515 sensor included (not shown)
- 7 bar/100 psi max. @ 20°C/68°F
- Max. installation/removal pressure: 1.7 bar/25 psi @ 22°C/72°F

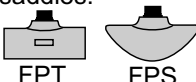
Fitting Types

Refer to Fitting Specification Sheets for detailed part numbers

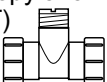
Type	Description	Type	Description
Plastic tees: PV8T CPV8T  PV8Txxx F CPV8Txxx F 	<ul style="list-style-type: none"> • 0.5 to 4 in. versions • PVC or CPVC • Mounts via glue-on fittings 	Threaded tees: •Iron (IR4T) •Carbon Steel (CS4T) •316 SS (CR4T) 	<ul style="list-style-type: none"> • 0.5 to 2 in. versions • Mounts on threaded pipe ends
Plastic Saddles: PV8S (PVC) CPV8S (CPVC) 	<ul style="list-style-type: none"> • 2 to 4 in., cut 1-7/16 in. hole in pipe • 6 to 8 in., cut 2-1/4 in. hole in pipe • Pipes over 8 in., use iron or fiberglass saddle 	Fiberglass tees & saddles: FPT FPS 	<ul style="list-style-type: none"> • 1.5 in. to 8 in. PVDF insert • > 8 in. PVC insert • Special order over 12 in.
Iron strap-on saddles: IR8S 	<ul style="list-style-type: none"> • 2 to 4 in., cut 1-7/16 in. hole in pipe • Over 4 in., cut 2-1/4 in. hole in pipe • Special order over 12 in. 	Polypropylene (PPMT) 	Metric wafer fitting • For pipes DN 65 to 200 mm • PP or PVDF
Weldolets: Copper/Bronze (BR4B) Carbon Steel (CS4W) 316SS (CR4W) 	<ul style="list-style-type: none"> • 2 to 4 in., cut 1-7/16 in. hole in pipe • Over 4 in., cut 2-1/4 in. hole in pipe • Remove insert before welding • Installed by certified welder only • Special order over 12 in. 	Polypropylene (PPMT) PVDF (SFMT) 	Metric union fitting • For pipes from DN 15 to 50 mm • PP or PVDF

Installation

- Six common installation configurations are shown here as guidelines to help you select the best location in your piping system for a paddlewheel flow sensor.
- Always maximize distance between sensors and pump sources.

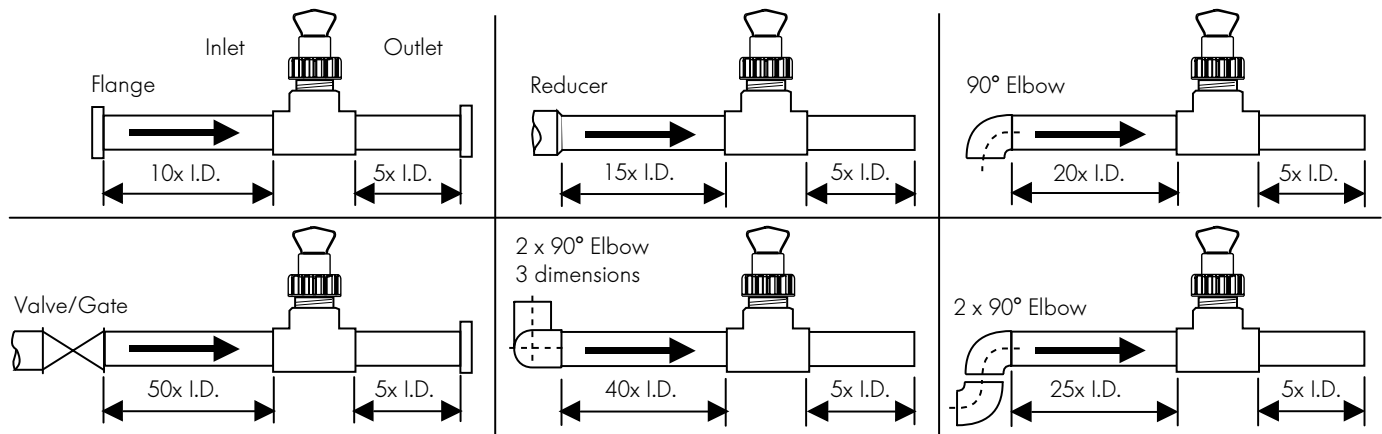

Sensor Mounting Position

- Horizontal pipe runs: Mount sensor in the upright (0°) position for best overall performance. Mount at a maximum of 45° when air bubbles are present. Do not mount on the bottom of the pipe when sediments are present.
- Vertical pipe runs: Sensor must be mounted in lines with UPWARD flow only.

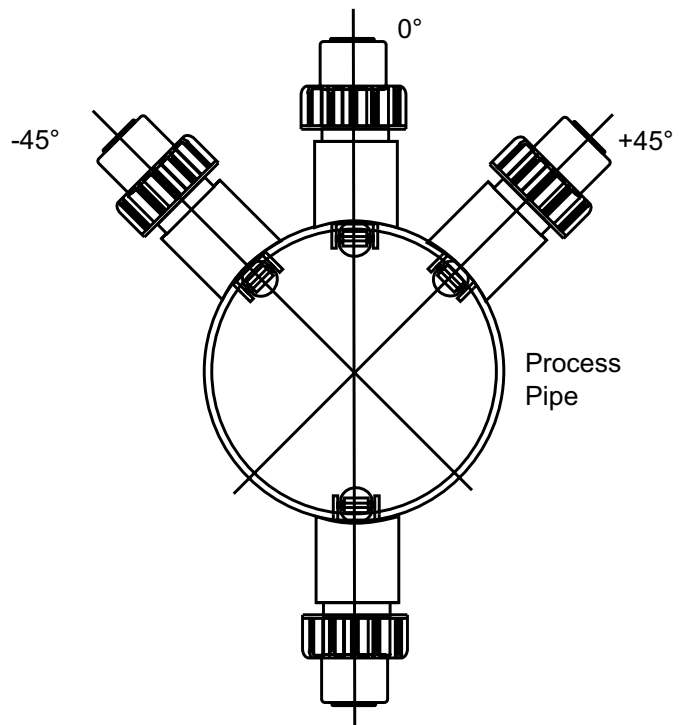

Wiring

515 Sensor Connection to +GF+ SIGNET Instruments

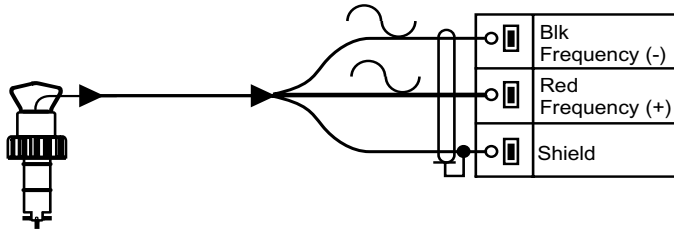

2536 Sensor Connection to +GF+ SIGNET Instruments

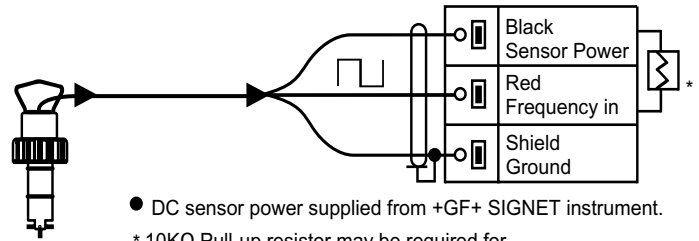

- DC sensor power supplied from +GF+ SIGNET instrument.
- * 10K Ω Pull-up resistor may be required for non-SIGNET brand instrument

Technical Data

General (for both 515 & 2536)

Pipe Size Range: 15 to 1000 mm (0.5 to 36 in.)

Linearity: $\pm 1\%$ of full range

Repeatability: $\pm 0.5\%$ of full range

Minimum Reynolds Number Required: 4500

Wetted Materials:

Sensor Body: Glass-filled Polypropylene (black) or PVDF (natural)

O-rings: FPM-Viton (std) or EPDM or FPM-Kalrez

Pin: Titanium or Hastelloy-C or PVDF; other materials options available

Rotor: Black PVDF or Natural PVDF; optional Tefzel with or w/o Fluoralloy B sleeve

Cable Type: 2-conductor twisted pair with shield (22 AWG)

Weight:

-X0	454 grams
-X1	476 grams
-X2	680 grams
-X3	794 grams
-X4	850 grams
-X5	1 kg
P31940	1.2 kg

Standards and Approvals (for both 515 & 2536):

- Manufactured under ISO 9001
- CE

General (515 Only)

Flow Rate Range: 0.3 to 6 m/s (1 to 20 ft./s)

Pipe Size Range: DN15 to DN1000 (0.5 to 36 in.)

Cable Length: 7.6 m (25 ft.)/60 m (200 ft.) maximum

Signal:

Frequency: 19.7 Hz per m/s nominal (6 Hz per ft/s)

Amplitude: 3.3 V p/p per m/s nominal (1 V p/p per ft/s)

Source Impedance: 8 K Ω

Standards and Approvals (515 only):

- FM Class I, II, III/Div./groups A-G

General (2536 Only)

Flow Rate Range: 0.1 to 6 m/s (0.3 to 20 ft./s)

Pipe Size Range: DN15 to DN1000 (0.5 to 36 in.)

Cable Length: 7.6 m (25 ft.)/300 m (1,000 ft.) maximum

Signal:

Frequency: 49Hz per m/s nominal (15 Hz per ft/s nominal)

Supply voltage: 3.5 to 24 VDC regulated

Supply current: <1.5 mA @ 3.3 to 6 VDC
<20 mA @ 6 to 24 VDC

Output Type: Open collector transistor, sinking

Output Current: 10 mA max.

Fluid Conditions

Sensor Pressure / Temperature Ratings:

Glass-filled Polypropylene Body:

12.5 bar (180 psi) max. @ 20°C (68°F)

1.7 bar (25 psi) max. @ 90°C (194°F)

PVDF Body:

14 bar (200 psi) max. @ 20°C (68°F)

1.7 bar (25 psi) max. @ 100°C (212°F)

319 Wet-Tap Assembly:

7 bar (100psi) max. @ 20°C (68°F)

1.7 bar (25 psi) max. @ 66°C (150°F)

Note: Wet-tap max. installation/removal pressure:

25 psi @ 22°C (72°F).

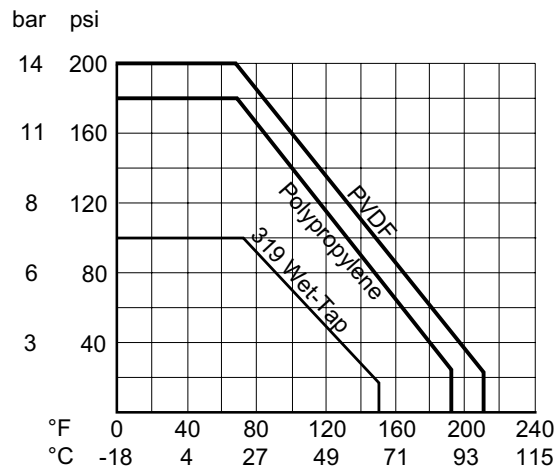

Ordering Information

515/8510-XX (Sinusoidal)

Mfr. Part No.	Code	Pipe Sizes	Body	Rotor/Pin	Installation
P51530-H0	198 801 659	0.5 to 4 in.	Polypro	Blk PVDF/Hastelloy-C	Remote
P51530-P0	198 801 620	0.5 to 4 in.	Polypro	Blk PVDF/Titanium	Remote
P51530-P1	198 801 621	5 to 8 in.	Polypro	Blk PVDF/Titanium	Remote
P51530-P2	198 801 622	10 to 36 in.	Polypro	Blk PVDF/Titanium	Remote
P51530-P3	198 840 310	0.5 to 4 in.	Polypro	Blk PVDF/Titanium	Remote Wet-Tap
P51530-P4	198 840 311	5 to 8 in.	Polypro	Blk PVDF/Titanium	Remote Wet-Tap
P51530-P5	198 840 312	10 to 36 in.	Polypro	Blk PVDF/Titanium	Remote Wet-Tap
P51530-S0	198 801 661	0.5 to 4 in.	Polypro	Blk PVDF/Natural PVDF	Remote
P51530-T0	198 801 663	0.5 to 4 in.	Natural PVDF	Natural PVDF	Remote
P51530-T1	198 801 664	5 to 8 in.	Natural PVDF	Natural PVDF	Remote
P51530-V0	198 801 623	0.5 to 4 in.	Natural PVDF	Nat. PVDF/Hastelloy-C	Remote
P51530-V1	198 801 624	5 to 8 in.	Natural PVDF	Nat. PVDF/Hastelloy-C	Remote
P51530-V2	198 801 625	10 to 36 in.	Natural PVDF	Nat. PVDF/Hastelloy-C	Remote
3-8510-P0	198 864 504	0.5 to 4 in.	Polypro	Blk PVDF/Titanium	Integral
3-8510-P1	198 864 505	5 to 8 in.	Polypro	Blk PVDF/Titanium	Integral
3-8510-T0	159 000 622	0.5 to 4 in.	Natural PVDF	Natural PVDF	Integral
3-8510-V0	198 864 506	0.5 to 4 in.	Natural PVDF	Nat. PVDF/Hastelloy-C	Integral

2536/8512-XX (Open-Collector)

3-2536-P0	198 840 143	0.5 to 4 in.	Polypro	Blk PVDF/Titanium	Remote
3-2536-P1	198 840 144	5 to 8 in.	Polypro	Blk PVDF/Titanium	Remote
3-2536-P2	198 840 145	10 to 36 in.	Polypro	Blk PVDF/Titanium	Remote
3-2536-T0	198 840 149	0.5 to 4 in.	Polypro	Natural PVDF	Remote
3-2536-V0	198 840 146	0.5 to 4 in.	Natural PVDF	Nat. PVDF/Hastelloy-C	Remote
3-2536-V1	198 840 147	5 to 8 in.	Natural PVDF	Nat. PVDF/Hastelloy-C	Remote
3-8512-P0	198 864 513	0.5 to 4 in.	Polypro	Blk PVDF/Titanium	Integral
3-8512-P1	198 864 514	5 to 8 in.	Polypro	Blk PVDF/Titanium	Integral
3-8512-T0	198 864 518	0.5 to 4 in.	Natural PVDF	Natural PVDF	Integral
3-8512-V0	198 864 516	0.5 to 4 in.	Natural PVDF	Nat. PVDF/Hastelloy-C	Integral

Wet-Tap Sensor and Valve Assembly (Fitting Separate)

MK319/515-P3	198 840 119	0.5 to 4 in.	Polypro	Blk PVDF/Titanium	Remote Wet-Tap
MK319/515-P4	198 840 120	5 to 8 in.	Polypro	Blk PVDF/Titanium	Remote Wet-Tap
MK319/515-P5	198 840 121	10 to 36 in.	Polypro	Blk PVDF/Titanium	Remote Wet-Tap

Accessories

Rotors 515/8510-XX

Mfr. Part No.	Code	Description
M1538-2	198 801 181	Rotor, PVDF Black
P51547-3	159 000 474	Rotor, PVDF Natural
M1538-4	198 820 018	Rotor, Tefzel
P51550-3	198 820 043	Rotor and Pin, PVDF Natural
3-0515.322-1	198 820 059	Sleeved Rotor, PVDF Black
3-0515.322-2	198 820 060	Sleeved Rotor, PVDF Natural
3-0515.322-3	198 820 017	Sleeved Rotor, Tefzel

Accessories (continued)

Rotors 2536/8512-XX

Mfr. Part No.	Code	Description
3-2536.320-1	198 820 052	Rotor, PVDF Black
3-2536.320-2	159 000 272	Rotor, PVDF Natural
3-2536.320-3	159 000 273	Rotor, Tefzel
3-2536.321	198 820 054	Rotor and Pin, PVDF Natural
3-2536.322-1	198 820 056	Sleeved Rotor, PVDF Black
3-2536.322-2	198 820 057	Sleeved Rotor, PVDF Natural
3-2536.322-3	198 820 058	Sleeved Rotor, Tefzel

Rotor Pins

M1546-1	198 801 182	Pin, Titanium
M1546-2	198 801 183	Pin, Hastelloy-C
M1546-3	198 820 014	Pin, Tantalum
M1546-4	198 820 015	Pin, Stainless Steel
P51545	198 820 016	Pin, Ceramic

O-Rings

1220-0021	198 801 186	O-Ring, FPM-Viton
1224-0021	198 820 006	O-Ring, EPDM
1228-0021	198 820 007	O-Ring, FPM-Kalrez

Miscellaneous

P31536	198 840 201	Sensor Plug, Polypro
P31536-1	198 840 202	Sensor Plug, PVDF Metric
P31536-2	159 000 649	Sensor Plug, PVDF
P31542	198 801 630	Sensor Cap, Red (for use w/515)
P31542-3	159 000 464	Sensor Cap, Blue (for use w/2536)
P31934	159 000 466	Conduit Cap
P51589	159 000 476	Conduit Adapter Kit
5523-0222	159 000 392	Cable, (per foot)
3-8051	159 000 187	Transmitter Integral Adapter

Engineering Specifications for both 515 and 2536 Flow Sensors

- The flow sensor shall use a four-blade, open-cell rotor design using insertion paddlewheel technology.
- Linearity of the output signal with respect to flow rate shall be $\pm 1\%$ of full range.
- Measurement repeatability of the output signal with respect to flow rate shall be $\pm 0.5\%$ of full range.
- The sensor body shall be made of injection-molded polypropylene (PP) that shall accommodate up to 12.5 bar @ 20°C (180 psi @ 68°F) and 1.7 bar @ 90°C (25 psi @ 194°F). As an alternative, the sensor shall be made of injection-molded polyvinylidene fluoride (PVDF) that shall accommodate up to 14 bar @ 20°C (200 psi @ 68°F) and 1.7 bar @ 100°C (25 psi @ 212°F).
- The sensor shall attach to a pipe via a variety of insertion-style installation fittings supplied by the flow sensor manufacturer. Attachment shall use a 1-1/4 X 11-1/2 NPSM threaded cap. Sealing shall be accomplished with a double O-ring seal. O-rings shall be made of FPM-Viton, FPM-Kalrez or EPDM.
- The sensor shall be equipped with 0.5 in. female conduit connection.

Engineering Specifications for +GF+ SIGNET 515 Rotor-X Flow Sensor

- The sensor shall require no electrical power.
- The sensor shall provide an output signal of 3.3 V p-p per m/s nominal (1 V p-p per ft/s) at a frequency of 19.7 Hz per m/s nominal (6 Hz per ft/s) from 0.3 to 6 m/s (1 to 20 ft/s).
- Output shall be via a twisted pair, foil-shielded cable with drain wire. Supplied cable shall be at least 7.6 m (25 ft) long, with a maximum allowable length of 60 m (200 ft).
- The operating range of the sensor shall accommodate nominal flow rates from 0.3 to 6 m/s (1 to 20 ft/s).
- The sensor shall meet appropriate CE standards and FM standards for Classes 1, 11 and 111, Division I/Groups A-G.

Engineering Specifications for +GF+ SIGNET 2536 Low Flow Sensor

- The sensor shall operate with a power input of 3.3 to 6VDC @ <1.5 mA or from 6 to 24 VDC @ <20 mA.
- The sensor output shall provide an open-collector pulse at a frequency of 49.2 Hz per m/s nominal (15 Hz per ft/s).
- Output shall be via a twisted pair, foil-shielded cable with drain wire. Supplied cable shall be at least 7.6 m (25 ft) long, with a maximum allowable length of 300 m (1000 ft).
- The operating range of the sensor shall accommodate nominal flow rates from 0.1 to 6 m/s (0.3 to 20 ft/s).
- The sensor shall meet appropriate CE standards.