

+GF+ SIGNET 2540/2517 High Performance Flow Sensors

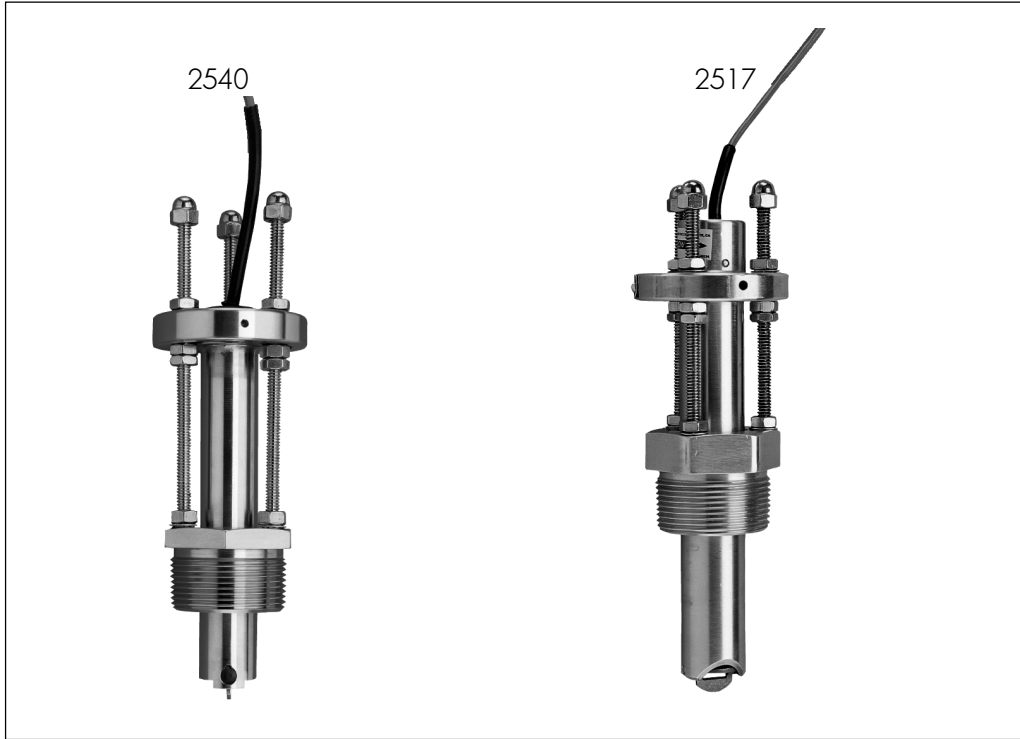

Features

- 316SS or Brass Construction
- Measures flow rates as low as 0.1 m/s (0.3 ft/s)
- Standard NPT or ISO process connections
- Hot-tap versions for installation/service without system shutdown
- Non-magnetic RF detection (2540)

Application

- HVAC
- Turf Irrigation
- Cooling Systems
- Filtration Systems
- Water Distribution
- Leak Detection
- Pump Protection
- Clarified Effluent Totalization
- Ground Water Remediation

Description

The +GF+ SIGNET 2540 offers the added strength and corrosion resistance of stainless steel for applications with low velocity measurements. Unique internal circuitry eliminates the need for magnets in the process fluid, enabling lower flow measurement while maintaining the advantages of insertion sensor design. Now utilizing Fluoroloy B bearings and Tungsten Carbide pin for

exceptional wear resistance. Improved circuitry provides greater immunity to large voltage disturbances encountered in field wiring. The 2517 Brass High Performance sensor signal allows for remote totalization when coupled with the 5100 Battery operated Flow Monitor.

Options

Flow Sensors	Instrument Options							
	8550-1	8550-2	8550-3	3-5075	3-5100	3-5500	3-5600	3-9010
2517	●	●	●	●	●	●	●	●
2540	●	●	●	●	●	●	●	●

Technical Features

- 1/2 in. NPT Conduit Port
- Solid 316SS or brass construction
- Standard 1-1/2 in. NPT or ISO 7/R 1-1/2 in. connection
- Low Mass open cell rotor and Tungsten Carbide pin for greater resistance to wear
- Hot-tap version with bleed valve
- Standard Viton O-rings (EPR optional)

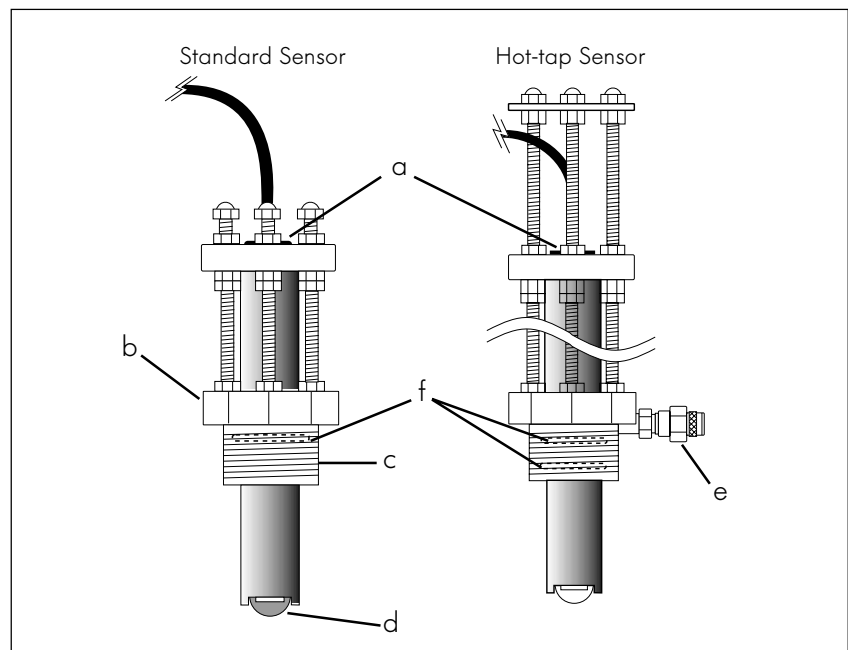

Wiring

2517 Sensor Connections to +GF+ SIGNET Instruments

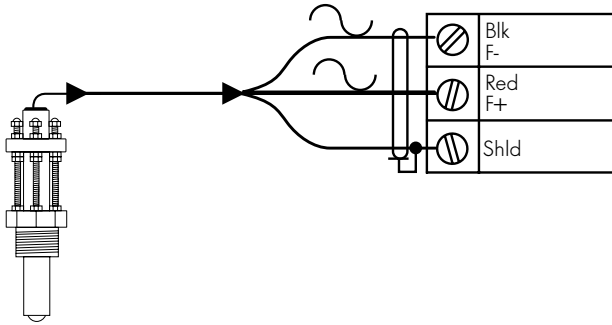

2540 Sensor Connections to +GF+ SIGNET Instruments

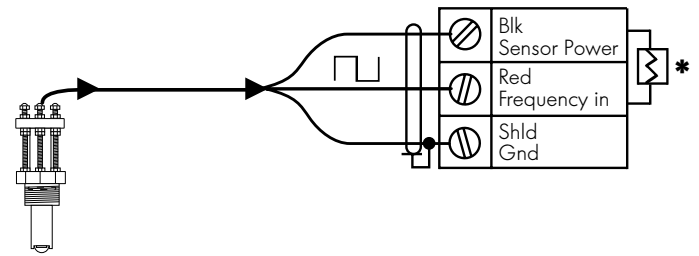

• DC sensor power supplied from +GF+ SIGNET instrument.

* 10KΩ Pull-up resistor may be required for non-SIGNET brand instrument

Dimensions

- 3 ft. recommended clearance for Hot-tap installation
- 16" recommended clearance for 2540, 2517

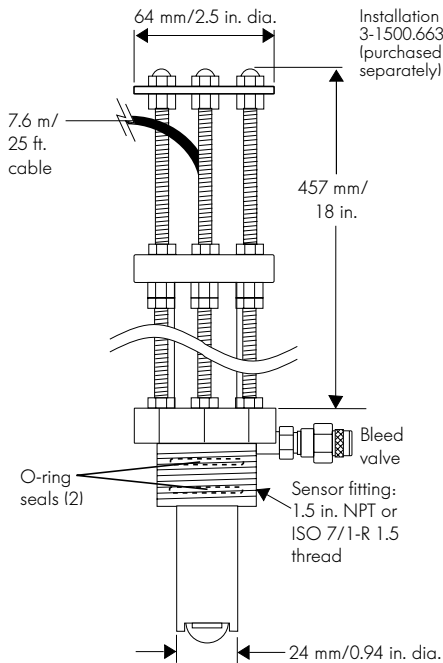

2540/2517 Hot-Tap for 1.5 to 36 in. pipes

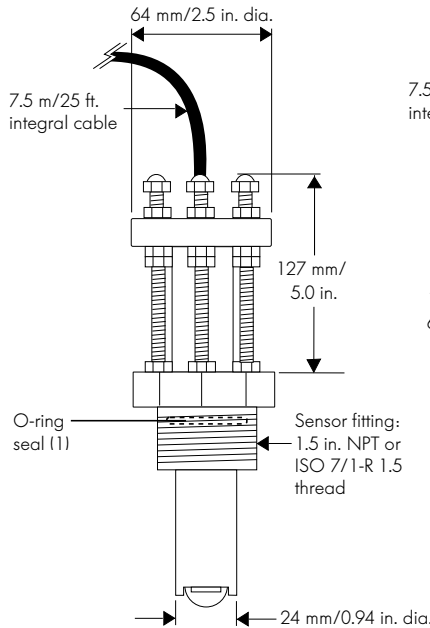

2540 High Performance Flow Sensor for 1.5 to 24 in. pipes

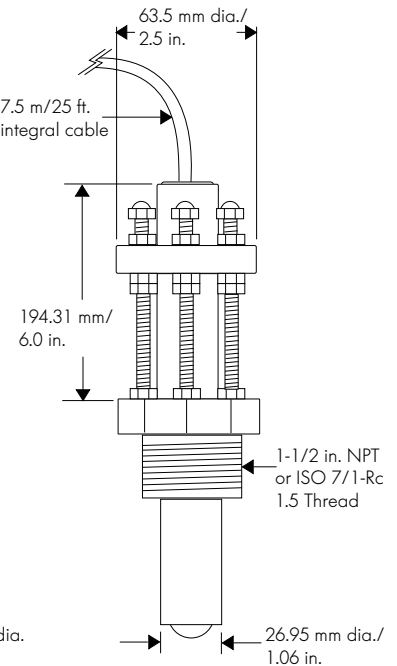

2517 Brass High Performance Flow Sensor for 1.5 to 24 in. pipes

Installation

Six common installation configurations are shown here as guidelines to help you select the best location in your system for a paddlewheel flow sensor. Always maximize distance between sensor and pump sources.

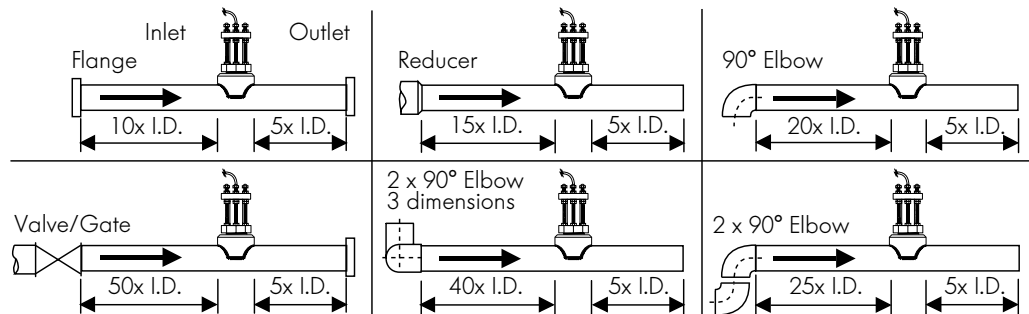

Sensor Mounting Position

2540

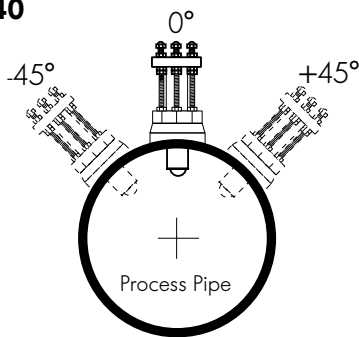

2517

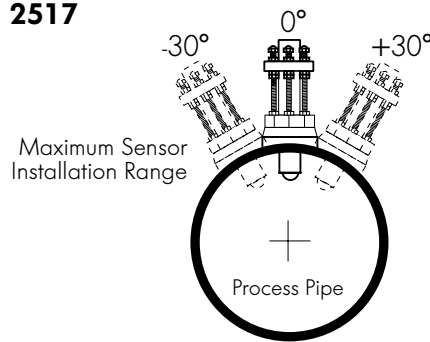

Technical Data

General

Flow Rate Range:

2540: 0.1 to 6 m/s (0.3 to 20 ft/s)

2517: 0.5 to 6 m/s (1.6 to 20 ft/s)

Linearity: $\pm 1\%$ of full range

Repeatability: $\pm 0.5\%$ of full range

Minimum Reynolds Number Required: 4500

Maximum operating pressure/temperature:

Sensor with standard Viton® sensor fitting O-rings: 17 bar (250 psi) @ 82°C (180°F)

Sensor with optional EPR sensor fitting O-rings: 17 bar (250 psi) @ 100°C (212°F)

Pipe range:

Standard version: 38 to 610 mm (1.5 to 24 in.)

Hot-Tap version: 38 to 1000 mm (1.5 to 36 in.)

Sensor fitting options: 1.5in NPT threads

ISO 7/1-R 1.5 threads

Cable length: 7.6 m (25 ft.), can splice up to 300 m (1,000 ft.)

Cable type: 2-conductor twisted-pair with shield

Wetted Materials (2540)

Sensor body: 316 Stainless Steel
Sensor fitting: 316 Stainless Steel
Sensor fitting O-rings: Standard Viton®, optional EPR
Rotor: CD4MCu stainless steel
Rotor pin: Tungsten Carbide GRP 1, 316
Retainers (2): 316 stainless steel
Rotor bearings (2): Fluoroloy B®

Wetted Materials (2517)

Sensor body: C36000 Free cutting brass
Sensor fitting: C36000 Free cutting brass
Sensor fitting O-rings: Standard Viton®, opt. EPR
Rotor: CD4MCu stainless steel
Rotor pin: Tungsten Carbide GRP 1, 316
Retainers (2): 316 stainless steel
Rotor bearings (2): Fluoroloy B®

Signal (2517)

Frequency: 20 Hz per ft/s nominal, 5 to 8 mV p-p per Hz

Source Impedance: 11.6 K Ω

Signal (2540)

Frequency: 15 Hz per ft/s nominal

Supply voltage: 5 to 24 VDC

Supply current: 1.5 mA max.

Output type: Open collector, sinking

Output current: 10.0 mA max.

Weight:

3-2540-1, -2: 1.79 Kg

3-2540-3, -4: 2.15 Kg

3-2517.100, .101: 2.04 Kg

3-2517.102, .103: 2.63 Kg

Standards and Approvals

- Manufactured under ISO 9001
- CE (2540 only)

Ordering Information

Mfr. Part No.	Code	Description
3-2540-1	198 840 035	High Performance Flow Sensor with 1.5 in. NPT thread
3-2540-2	198 840 036	High Performance Flow Sensor with 1.5 in. ISO thread
3-2540-3	198 840 037	Hot-Tap Flow Sensor with 1.5 in. NPT thread
3-2540-4	198 840 038	Hot-Tap Flow Sensor with 1.5 in. ISO thread
3-2517.100	198 840 003	Brass High Performance Flow Sensor with 1.5 in. NPT thread
3-2517.101	198 840 007	Brass High Performance Flow Sensor with 1.5 in ISO thread
3-2517.102	159 000 267	Brass Hot-Tap Flow Sensor with 1.5 in. NPT thread
3-2517.103	159 000 268	Brass Hot-Tap Flow Sensor with 1.5 in. ISO thread

Accessories

3-1500.663	198 820 008	Hot-Tap Installation Tool
1220-0021	198 801 186	O-ring, Viton®
1224-0021	198 820 006	O-ring, EPR
1228-0021	198 820 007	O-ring, Kalrez
3-2540.320	159 000 286	Rotor Kit, 2540 Peek Bearing (old version)
3-2540.321	159 000 623	Rotor Kit, 2540 Tungsten Carbide Pin (new version since 1.1 .2000)
P52509-1	198 801 501	Rotor Kit, 316 SS Pin (2517 Sensor)
P52509-2	198 820 023	Rotor Kit, Tungsten Carbide Pin (2517 Sensor)
P52504-1	198 801 500	Pin, 316 SS (2517 Sensor)
P52504-2	198 820 023	Pin, Tungsten Carbide (2517 Sensor)
3-2540.520	159 000 648	Bearing, Flourolloy B® (2540 Sensor)
P52503	198 820 013	Bearing, Flourolloy B® (2517 Sensor)
P52527	159 000 481	Retainers, SS (2540 Sensor)
3-2517.567	159 000 269	Retainers, SS (2517 Sensor)
5523-0222	159 000 392	Cable, per ft.
P51589	159 000 476	Conduit Adapter Kit
P31934	159 000 466	Conduit Cap

Engineering Specifications for +GF+ SIGNET 2540 Sensor

- The flow sensor shall use a four-blade, open-cell rotor design using insertion paddlewheel technology.
- Sensor shall use non-magnetic sensing principle. The sensor shall operate with a power input of 5 to 24 VDC.
- The sensor shall be available in models usable in pipe sizes from 1.5 to 24 in. and 1.5 to 36 in. when combined with hot-tap assembly.
- The sensor output shall be an open-collector pulse at a frequency of 15 Hz per ft/s nominal.
- Output shall be via a twisted pair, foil-shielded cable with drain wire. Supplied cable shall be at least 7.6 m (25 ft) long, with a maximum allowable length of 300 m (1000 ft).
- Linearity of the output signal with respect to flow rate shall be $\pm 1\%$ of full range.
- Measurement repeatability shall be $\pm 0.5\%$ of full range.
- The operating range of the sensor shall accommodate nominal flow rates from 0.1 to 6 m/s (0.3 to 20 ft/s).
- The sensor body shall be made of ACI type CFR-8M (316 SS) per ASTM A351 that shall accommodate up to 250 psi @ 82°C (180°F) with Viton seals or up to 250 psi @ 100°C (212°F) with EPR seals.
- Rotor materials shall be CD4MCu alloy. Shafts shall be Tungsten Carbide.
- The sensor shall provide 1.5 in. NPT or ISO male pipe threads for attachment to a pipe. An installation fitting that includes an isolation valve and suitable hardware to allow complete installation in pipes containing fluid (Hot-Tap fittings) must be available.
- The sensor shall meet appropriate CE standards and shall be +GF+ SIGNET, Model 2540 High Performance.

Engineering Specifications for +GF+ SIGNET 2517 Sensor

- The flow sensor shall use a four-blade, open-cell rotor design using insertion paddlewheel technology.
- The sensor shall be available in models usable in pipe sizes from 1.5 to 24 in. and 1.5 to 36 in. when combined with hot-tap assembly.
- Linearity of the output signal with respect to flow rate shall be $\pm 1\%$ of full range.
- Measurement repeatability shall be $\pm 0.5\%$ of full range.
- The operating range of the sensor shall accommodate nominal flow rates from 0.5 to 6 m/s (1.6 to 20 ft/s).
- The sensor body shall be made of C36000 free cutting brass that shall accommodate up to 17 bar @ 100°C (250 psi @ 212°F).
- Rotor materials shall be CD4MCu alloy. Shafts shall be Tungsten carbide.
- The sensor shall provide 1.5 in. NPT or ISO male pipe threads for attachment to a pipe. An installation fitting that includes an isolation valve and suitable hardware to allow complete installation in pipes containing fluid (Hot-Tap fittings) must be available.